



ISTANBUL TECHNICAL UNIVERSITY

Faculty of Aeronautics and Astronautics

Department of Astronautical Engineering

ITU HISTORY

İTÜ



Taşkişla -1955

Imperial Naval Engineering School

1773



Gümüşsuyu 1975

School of Engineers and Architects

1909



Orta bahçe -1976

Higher School of Engineering

1944



Maritime Faculty Campus

1988



1795
Imperial School of Engineering



1914
First Engineer Graduates



1970
Ayazağa Main Campus



1974
Transition to two-tier undergraduate and graduate education



2024
251st Year



I.T.Ü Gümüşsuyu Binası



I.T.Ü Maçka Binası



Ayazaga Main Campus (8 Faculties)

- Faculty of Faculty of Civil Engineering
- Faculty of Electricity - Electronics
- Faculty of Mining
- Faculty of Chemical Metallurgy
- Faculty of Computer and Informatics
- Faculty of Science and Letters
- Faculty of Naval Architecture and Marine Sciences
- Faculty of Aviation and Space Sciences

Institutes

- Energy Institute
- Institute of Science and Technology
- Institute of Social Sciences
- Informatics Institute
- Eurasian Institute of Earth Sciences
- Earthquake Engineering and Disaster Management Institute



Taskisla Campus

- Faculty of Architecture
- Institute of Social Sciences



Macka Campus

- Faculty of Business Administration
- School of Foreign Languages
- Conservatory



Gumussuyu Campus

- Faculty of Mechanical Engineering
- Faculty of Textile Technologies and Design



Tuzla Campus

- Faculty of Maritime Studies

ITU ARI Teknokent

- A versatile, effective and sustainable university-industry cooperation
- 2,500 successful R&D Projects (148 patented)
- 276 R&D Companies
- 752 million dollars turnover

ITU Çekirdek Early Stage Incubation Center

- All entrepreneurs who have technological, innovative business ideas and believe that their ideas are innovative and can be turned into commercial activities

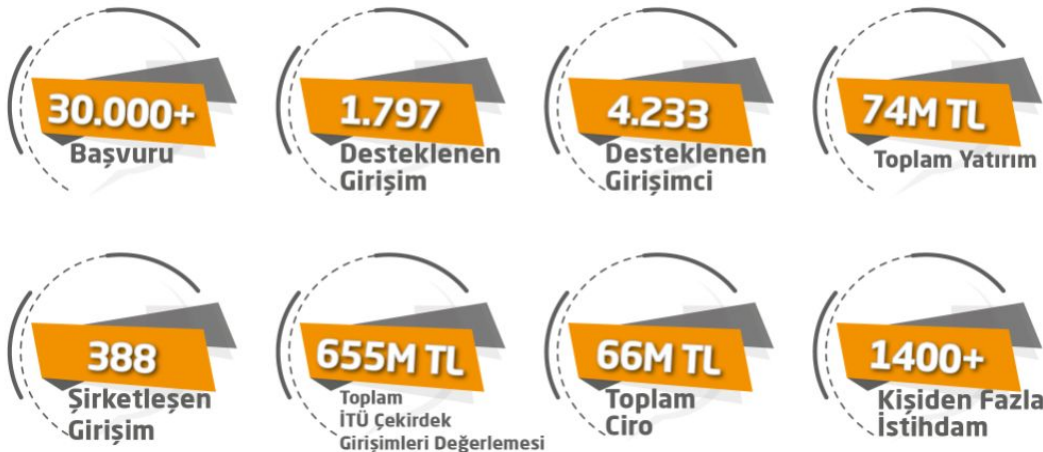

Academic Members

- 2,456 academics

Undergraduate Education

- 37,156 undergraduate students
 - 18 Dual Diploma Programs(SUNY)

Postgraduate Education

- 11,783 graduate students
 - 119 Master Program
 - 74 PhD Program

Graduates

- More than 140,000 graduates

Foreign Recognition



University	Country	Number of Accredited Programs	Accredited ABET Engineering Accreditation Commission
Istanbul Technical University	Türkiye	26	

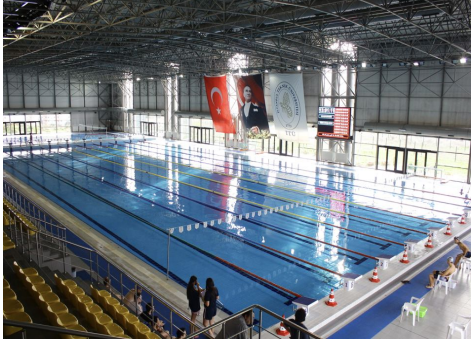

Sports Facilities

- **Gated Gyms** : Areas suitable for team sports such as basketball, volleyball and handball.
- **Fitness Centers** : Modern ekipmanlarla donatılmış spor salonları.
- **Open Area Facilities** : Football, tennis courts and an outdoor swimming pool.

Food and Beverage Areas

- **Campus Canteens** : A variety of food options at affordable prices for students.
- **Restaurants and Cafes** : Social spaces within the campus.

Culture and Art

- **Concerts and Events** : Concerts and theater performances organized by ITU Conservatory.
- **Club Activities** : More than 200 student clubs, giving you the chance to participate in activities that match your interests.

Social Activities

- **Festivals**: Spring festivals and sports festivals.
- **ITU Cinema Club** : Weekly film screenings and filmmaking workshops.



Ring Servisleri

Ayazağa Kampüsünde gün boyu ücretsiz sunulan ring servis ağını ve saatlerini görmek için tıklayın.



Bisiklet ile Ulaşım

Bisiklet kullanımı, "Yeşil Kampüs"te ulaşımın en kolay ve çevreci yolu. Bisiklet yolları haritası için tıklayın.



Otopark Kullanımı

İTÜ yerleşkelerinde güvenli ulaşım ve uyumlu bir ortak yaşam için uyulması gereken trafik kurallarını görmek için tıklayın.



Technology and Research Areas

- **Libraries** : Rich resources and workspaces.
- **Laboratories and Workshops** : Research centers equipped with the latest technology.

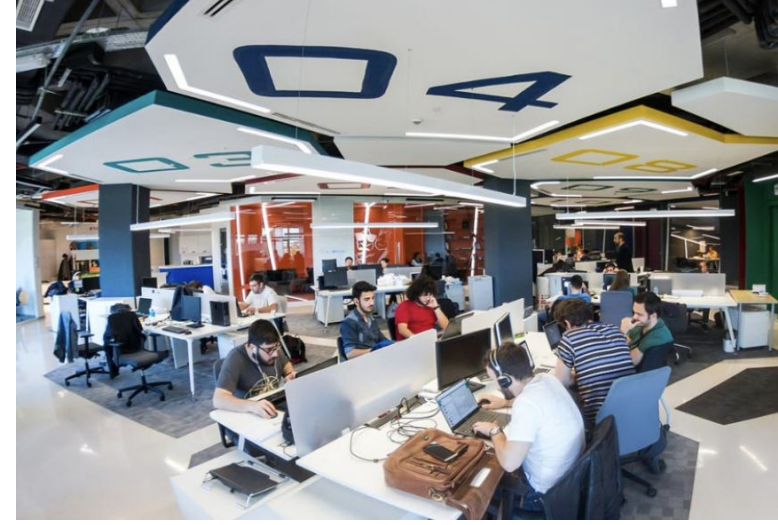

Transportation

- **On-Campus Transportation** : Ring services and walking paths.
- **Connection to the City**: Public transportation options such as metro, metrobus and buses.

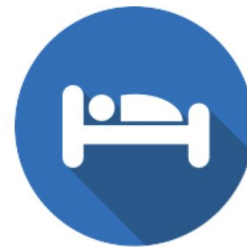

5300 Kişi

İTÜ Yurtlarında Kalan Öğrenci Sayısı



140 milyon TL

13100 Öğrencimize Verilen Burs Miktarı



6000 Kişi

Konuk Evinde Kalan Misafir Sayısı

LODGEMENT FACILITIES

İTÜ

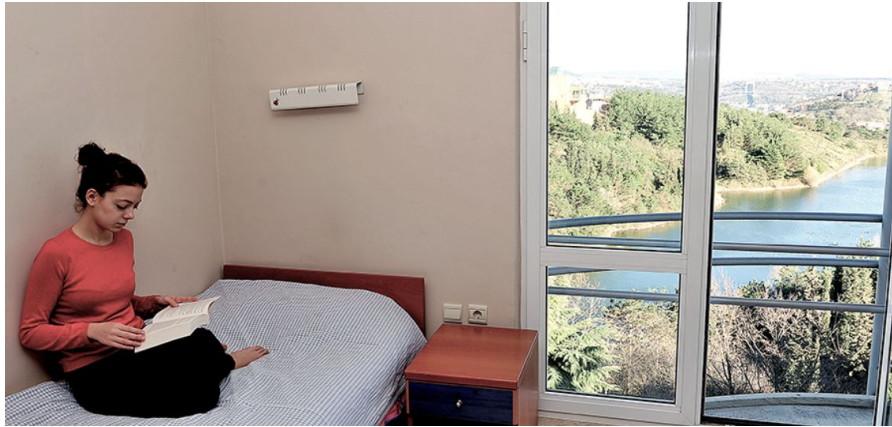

- Sports Hall
- Dining Hall
- Rest room
- Table tennis court
- Study room
- Shared kitchen



LODGEMENT FACILITIES

İTÜ



Red dots represent Gümüşsuyu Campus dormitories



Red dots represent Ayazağa Campus dormitories

1941

- Department of Aeronautical Engineering, It was established as a specialty branch under the Department of Mechanical Engineering.

1944

- Department of Aeronautical Engineering became a separate engineering department in the Faculty of Mechanical Engineering

1953

- Meteorological Engineering Department established within the Faculty of Electricity

1983

- **Faculty of Aeronautics and Astronautics** was established.
 - Aeronautical Engineering
 - Meteorological Engineering
 - Astronautical Engineering



Astronautical engineers design, test, manufacture, take part in the operation and continuity of

- manned space vehicles to be put into orbit around the Earth,
- unmanned satellites,
- rockets to place these vehicles into orbit,
- systems required for return to Earth from space,
- manned/unmanned space vehicles for deep space
- manned/unmanned exploration flights,
- propulsion systems, and
- robot systems, and develops the necessary technologies.
- **Faculty Member : 16**
- **Research Assistant : 12**
- **Technicians : 3**
- **Total Students :**
 - **472 Undergraduate**
 - **+300 Postgraduate**



Double Major Programs

- Aeronautical Engineering
- Control and Automation Engineering
- Metallurgical and Materials Engineering
- Mechanical Engineering
- Computer Engineering
- Artificial Intelligence and Data Engineering
- Electronics and Communication Engineering
- Electronic Engineering
- Electrical Engineering
- Telecommunication Engineering
- Management Engineering
- Industrial Engineering
- Mathematics Engineering
- Petroleum and Natural Gas Engineering
- Economy
- Mining Engineering
- Mineral Processing Engineering
- Textile Engineering
- Geomatics Engineering



ASTRONAUTICAL ENGINEERING MAIN RESEARCH AREAS

Astronautical Engineering program focuses on the basic areas that will meet the research, development, design, production and operation needs of the aviation, machinery and defense industries. For this reason, curriculum emphasizes disciplines such as

- Aerodynamics
- Propulsion Systems
- Structure and Materials
- Dynamics, Stability and Control

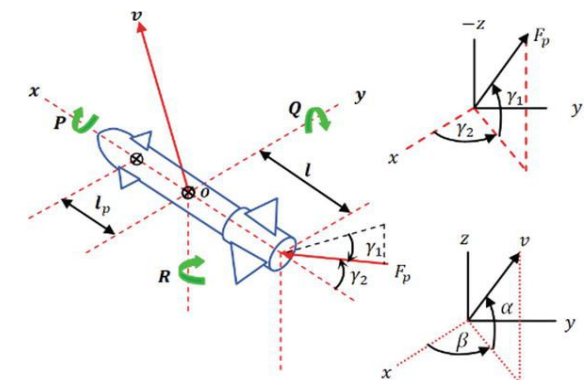
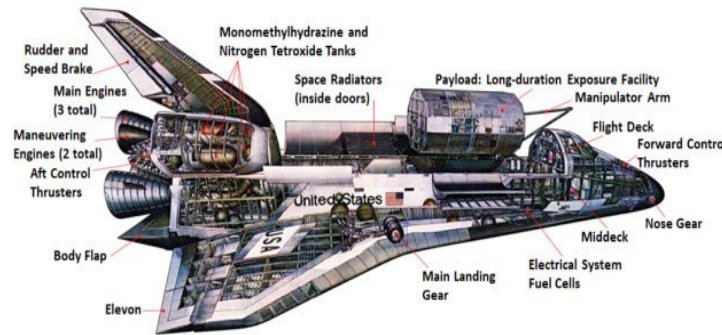
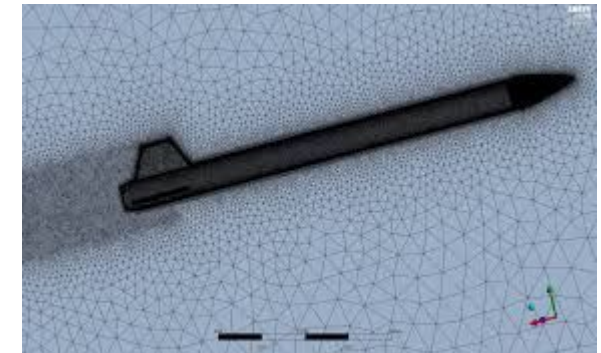
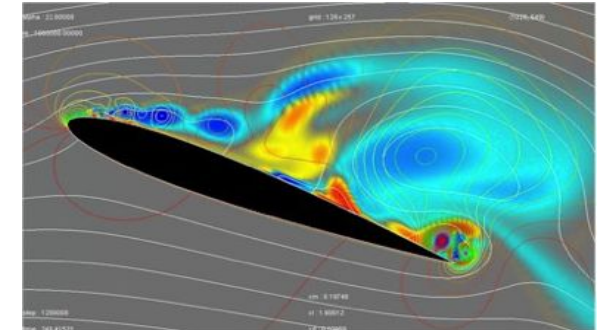

CONTROL

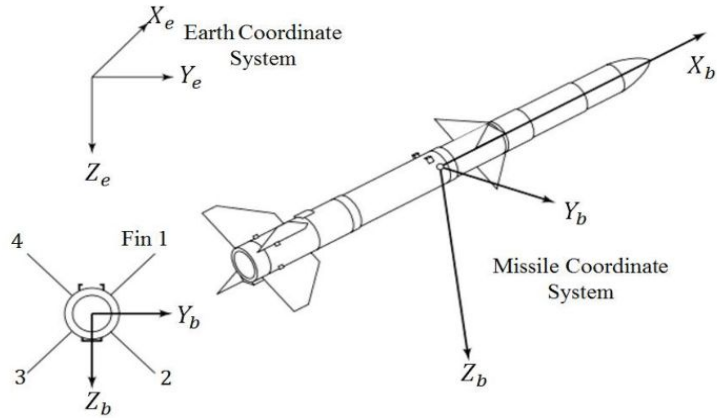

SPACE SHUTTLE

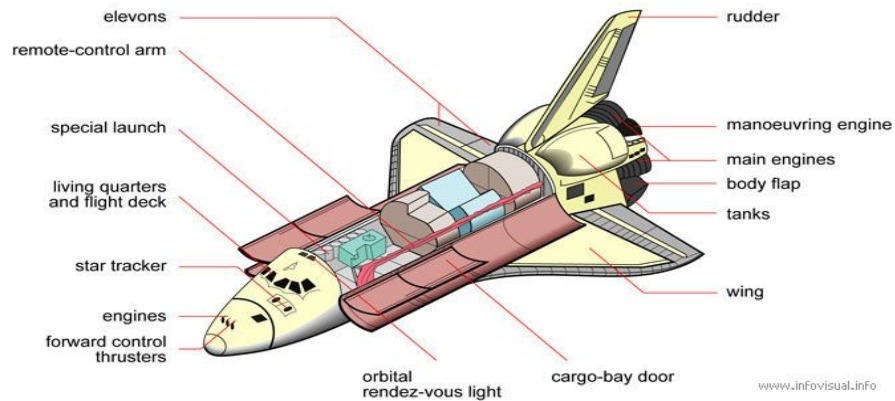

PROPULSION SYSTEMS

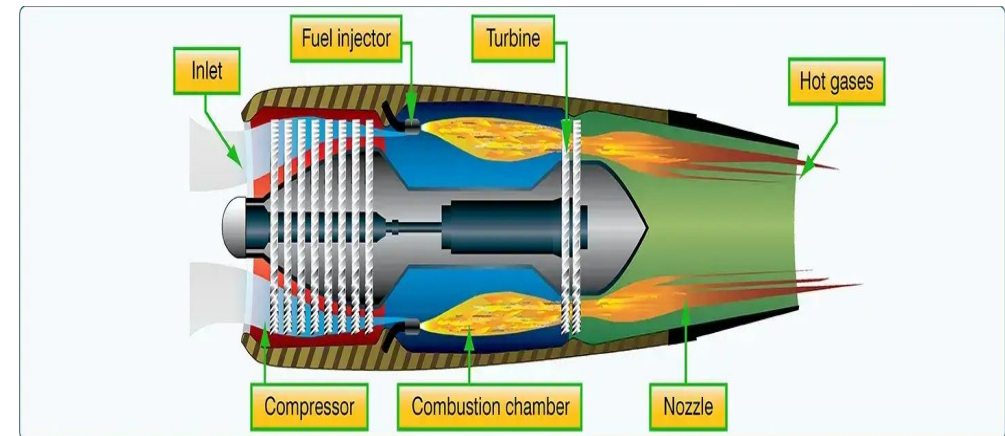

OTHER RESEARCH AREAS

- Aerodynamics and Fluid Dynamics
- Structural Design and Analysis
- Materials Technologies
- Multi-Disciplinary Analysis and Design Optimization
- Flight Control, Navigation, and Measurement Systems
- Model-Based Design and Control
- Rocket Engines
- Space Systems
- Wind Tunnel Technologies

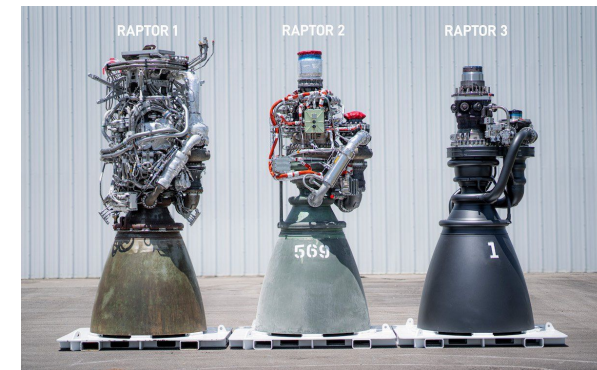
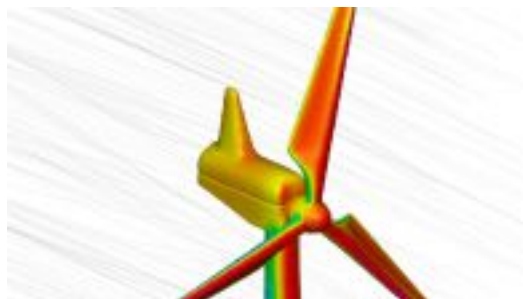
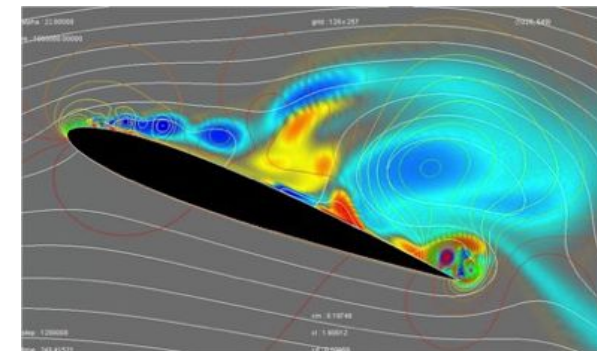
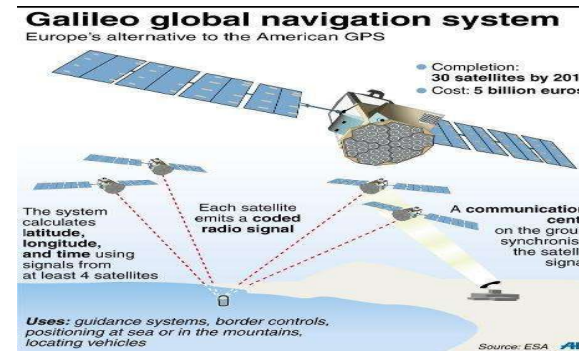

- Trisonic Laboratory
- Composite Structure Laboratory
- Computational Engineering Laboratory (HEMLAB)
- Aerospace Multidisciplinary Design Optimization Laboratory (AeroMDO Lab)
- Propulsion and Combustion Laboratory
- Model-Based Design Lab
- Aerospace Research Center
- Space Systems Design and Test Laboratory
- Cankut Bagana Innovation Lab (CBILAB)
- Mechanical and Vibration Lab
- Rotor Technologies Lab
- ITU-TUSAS Computational Engineering and ReDe Lab
- AI, Navigation and Control Lab
- Heat and Mass Transfer Lab

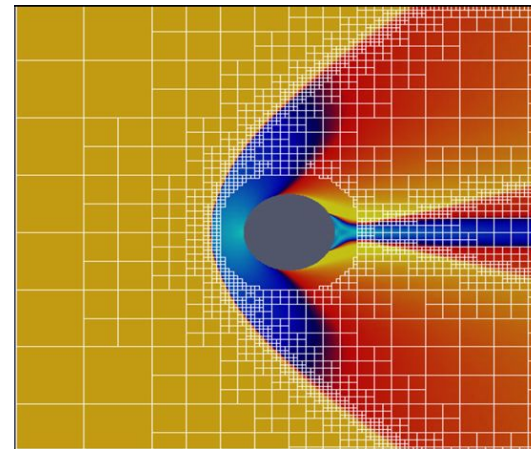

Research Topics:

- Aerodynamic and structural analysis of objects moving in air;
- Performance analysis of aircraft, engines and engine components

Facilities:

- Subsonic Wind Tunnel
(0 – 40 m/s)
- Supersonic Wind Tunnel
(0.2 – 4 M)
- Water Tunnel

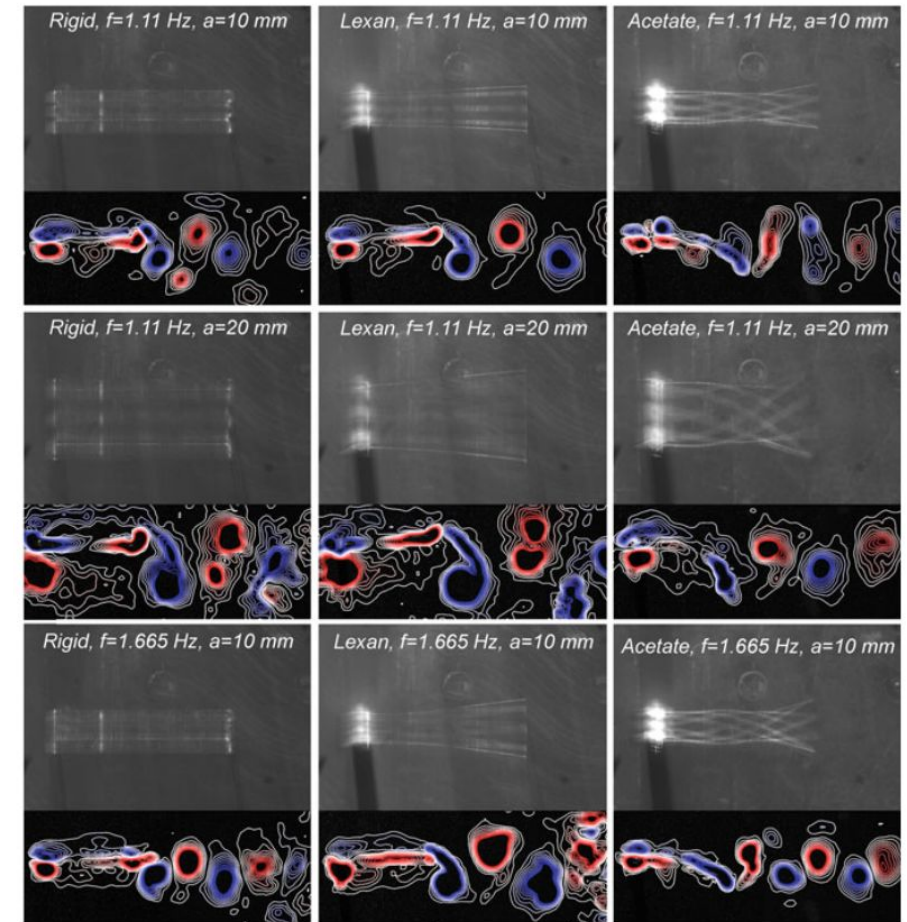
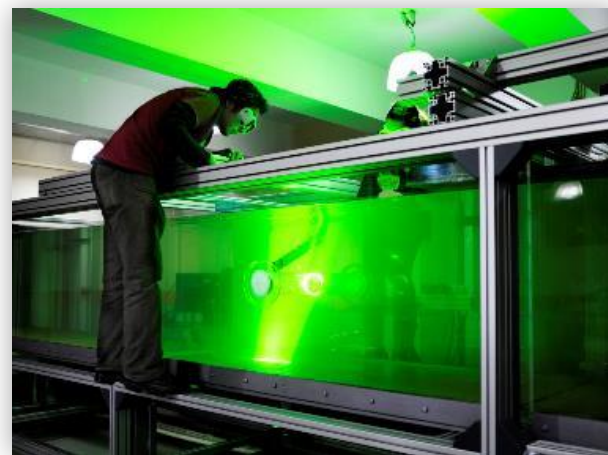

Effect of Chordwise Flexibility on Flapping Wing Aerodynamics

Research Topics:

- Testing and analysis of prototype and final design products

Test Capabilities:

- Tensile and compression tests
- Fatigue test
- Impact test



MTS testing frame: dynamical and statical testing



Testing a lightweight helicopter



Charpy – Izod impact test system

Conjugate Heat Transfer

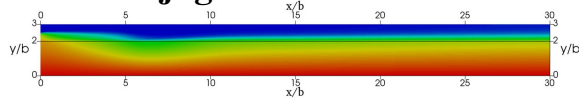

DNS of Turbulent Flow

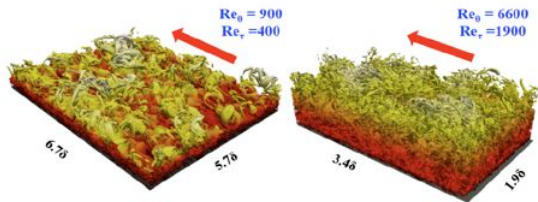

Low Reynolds Number Aerodynamics

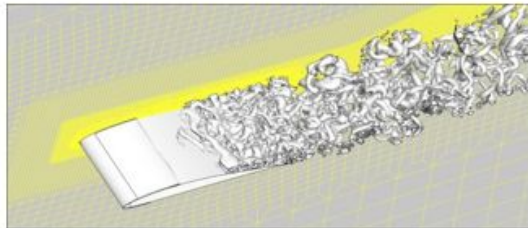

Animal Locomotion (Flying/Swimming Animals)

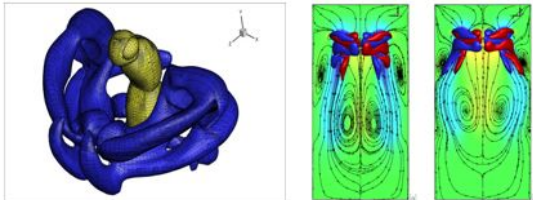

Blood Flow

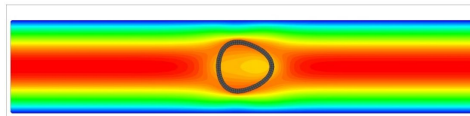

Fluid Structure Interaction

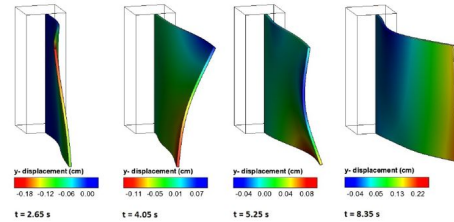

LES of Secondary Flows in Low-Pressure-Turbines

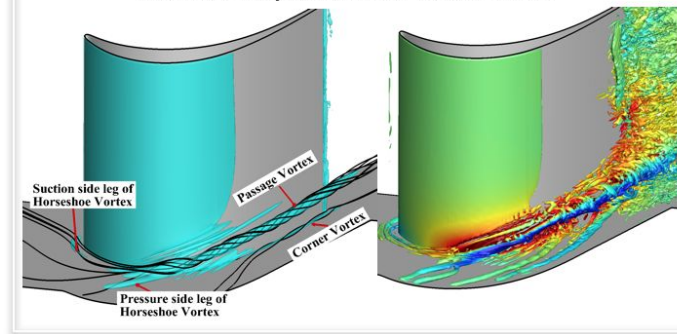

Vortex Dynamics

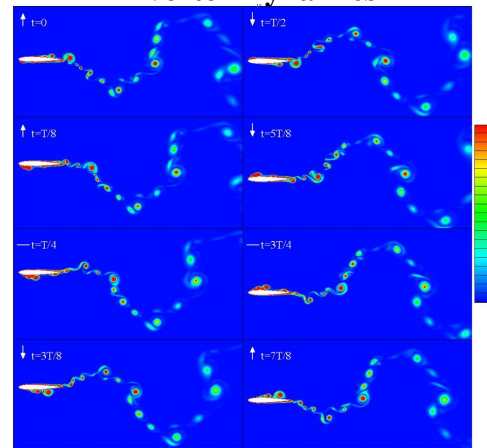

Mixing and Heat Transfer Enhancement

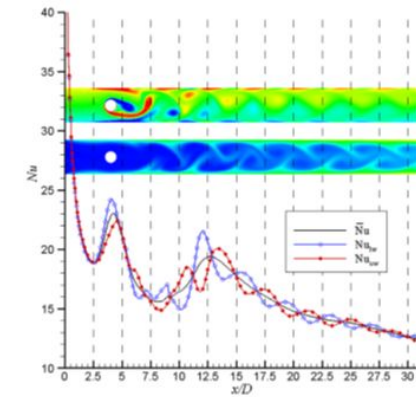

Viscoelastic Instabilities

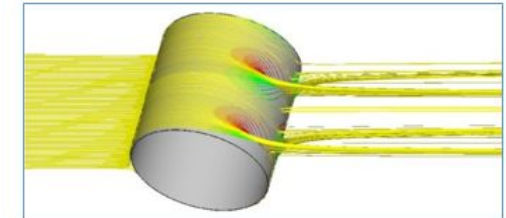

Shock wave – boundary layer interaction

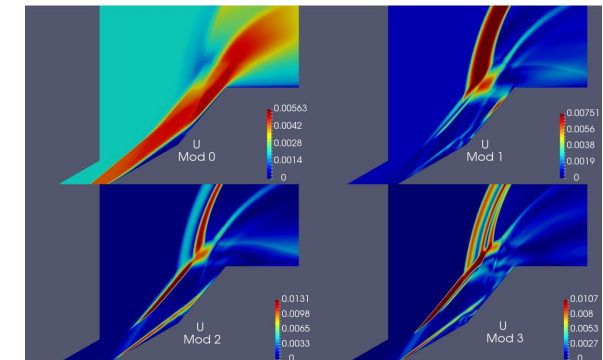

Research Topics:

- Experimental studies on engines, reactive flows and propulsion systems
- Different types of fuel
- Combustion reactions in porous media

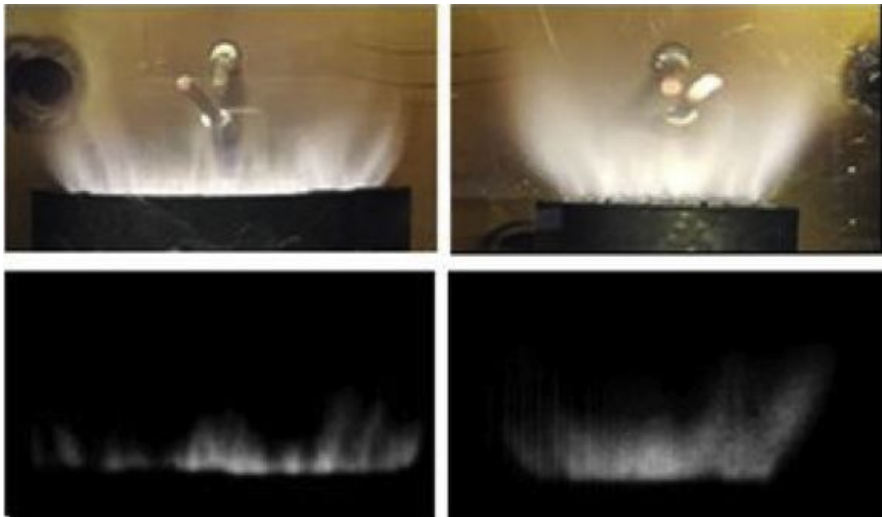

Porous medium based burner for efficient and clean combustion of ammonia-hydrogen-air systems

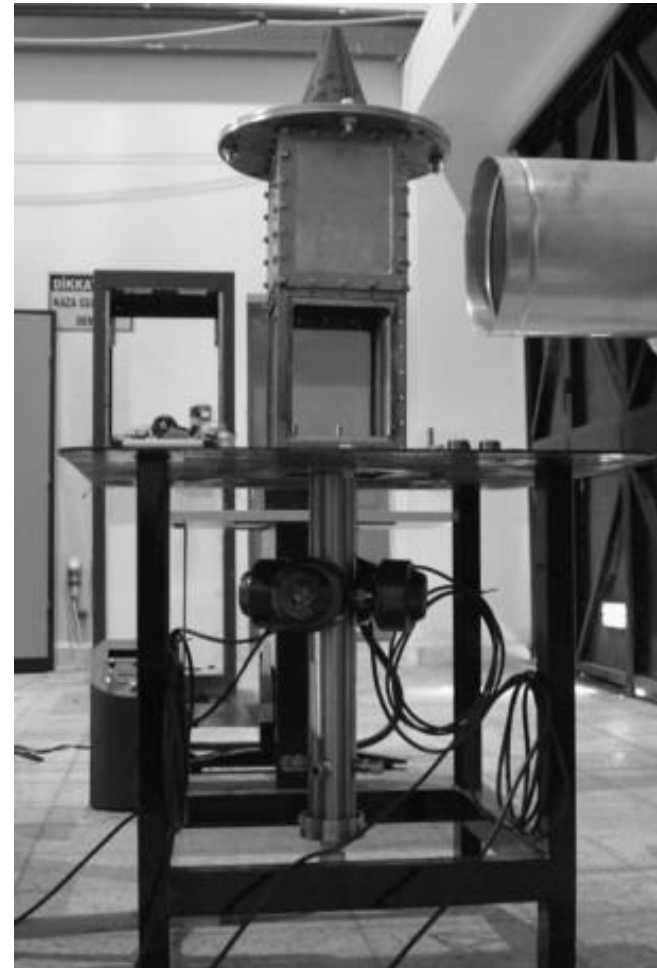

Preliminary investigation of a swirl stabilized premixed combustor

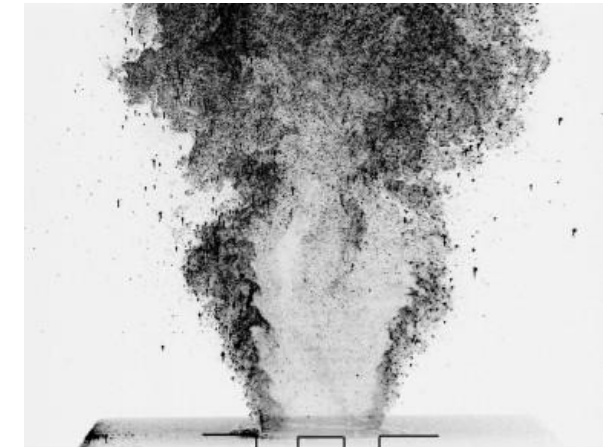

(a) Frame I

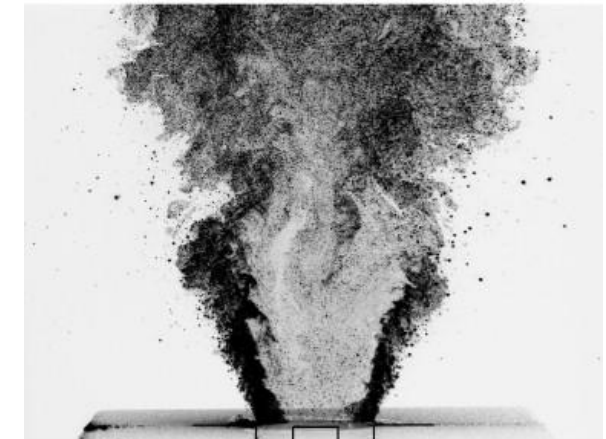

(b) Frame II

Purpose of the Lab:

Modeling, control systems and vehicle software development

Research Topics:

- Dynamic modeling and simulation
- Design of control systems
- Development of software for multi-physical systems
- Fixed and rotary wing unmanned aerial vehicles

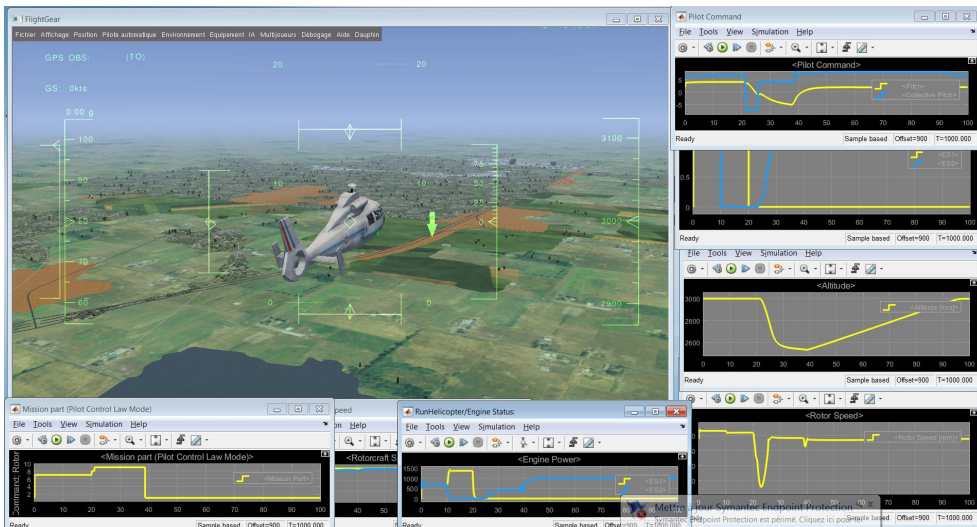
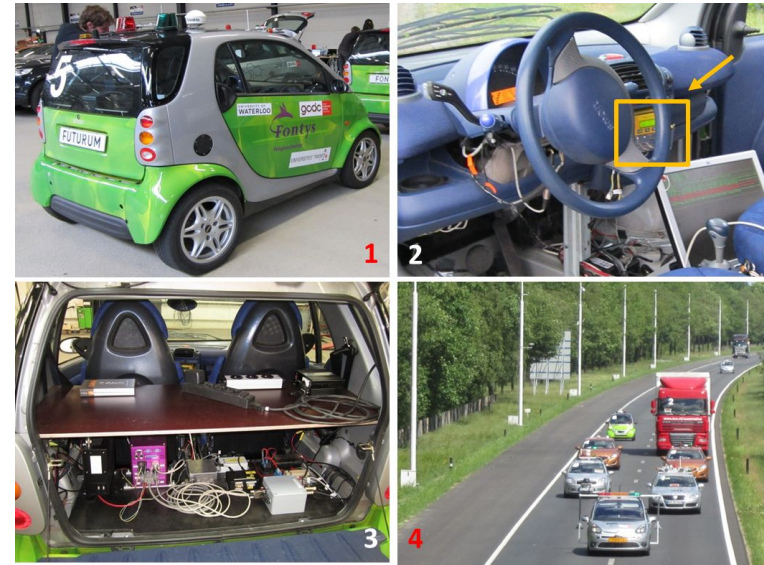

MODEL
sponsored by ITÜ

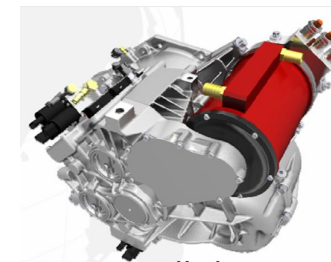

Hardware

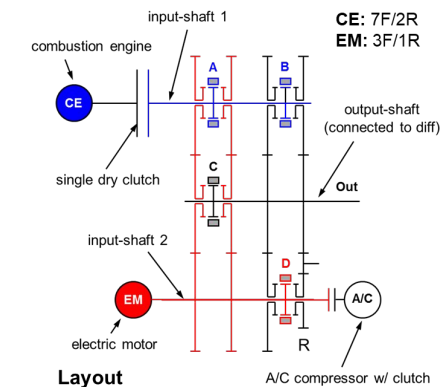

Plant Modeling of 7H-AMT

(Hybrid Automated Manual Transmission)

Multi-Physical Modeling, System Identification and Control System Design for Next Generation VTOL Systems

Nanomaterials, Textiles and Advanced Composites Research Group

Research Topics:

- Development and mechanical testing of nano-engineered materials
- Multiscale modeling of nanocomposites and laminated composites
- 3D printing methods of conductive structural materials
- Aircraft cabin filtration techniques
- Smart textile materials

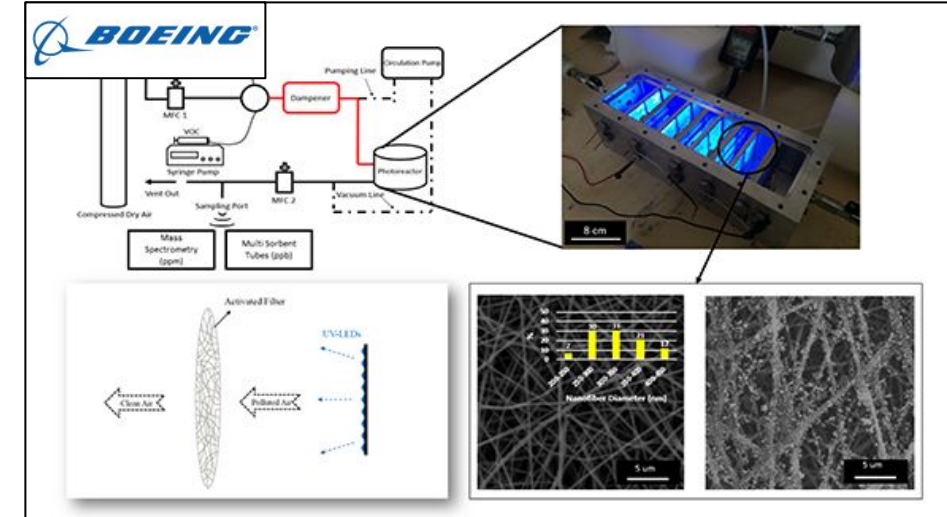

Advanced Filtration Technology for VOC Removal

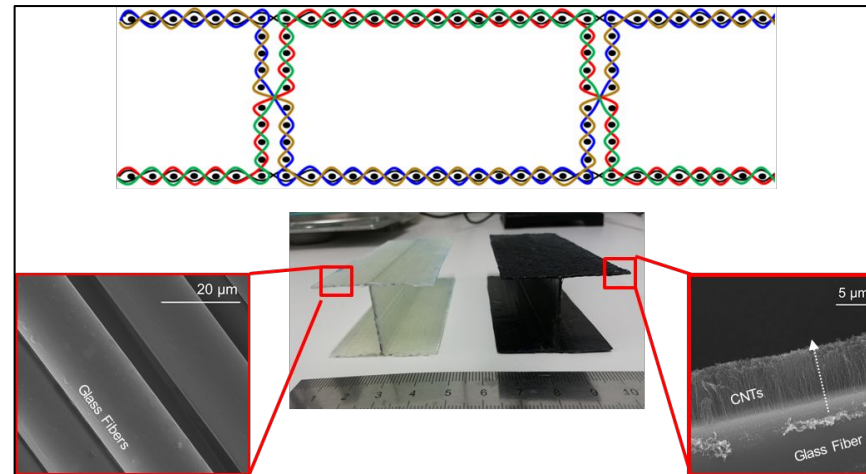

Nanoengineered Multifunctional 3D Woven Composites

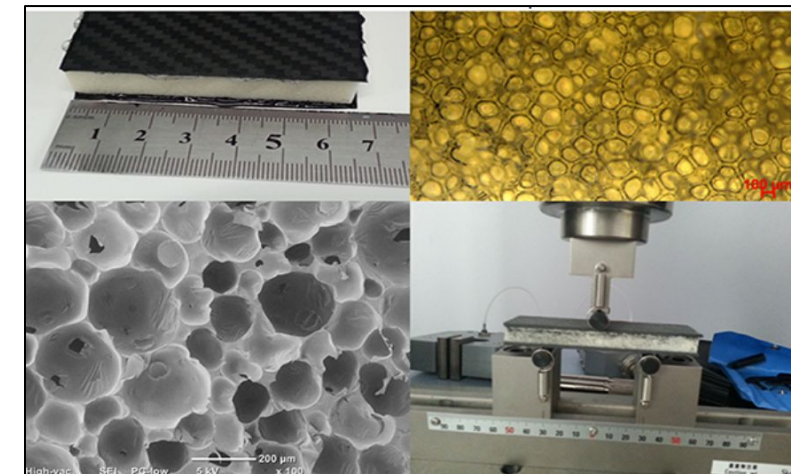

Investigation of Polymer Nanocomposite Foams for Sandwich Structures

Control and Avionics Research Group

Research Topics:

- Dynamic modeling of aircraft,
- Flight control systems design,
- Operation command and control system design and applications
- Artificial intelligence and machine learning applications

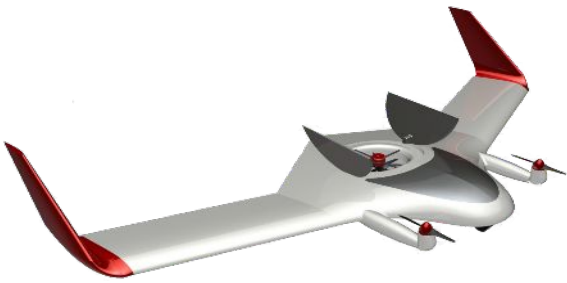

Turac – VTOL UAV

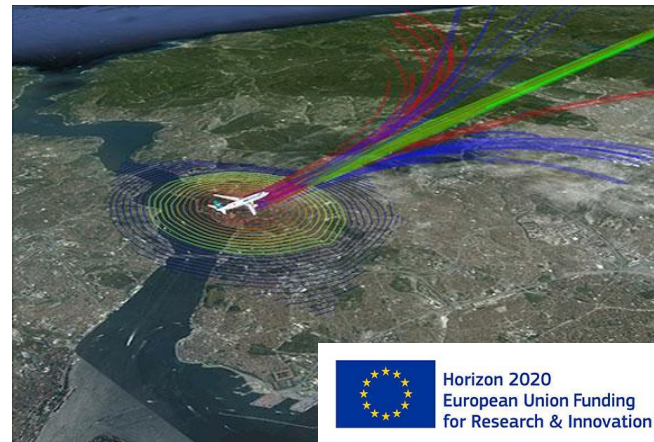

COPTRA – Combining Probable Trajectories

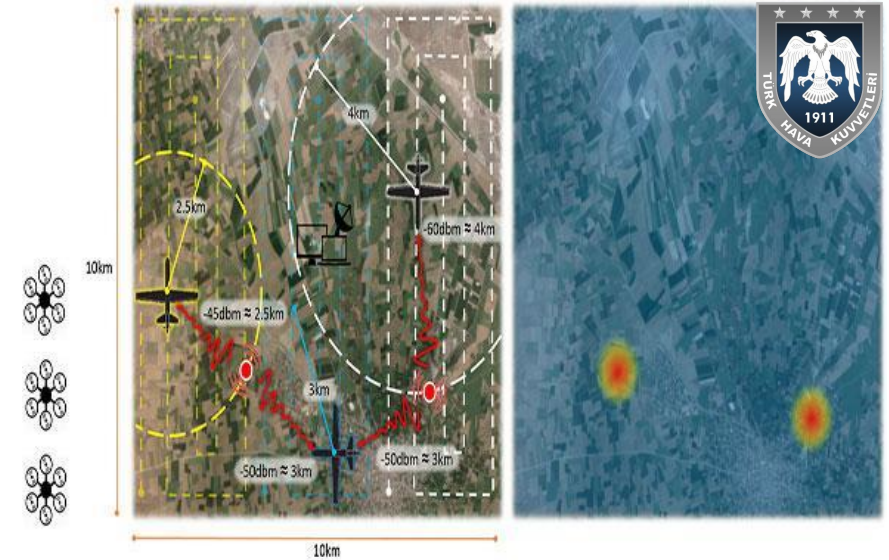

Search and Rescue Project with Multi UAVs System

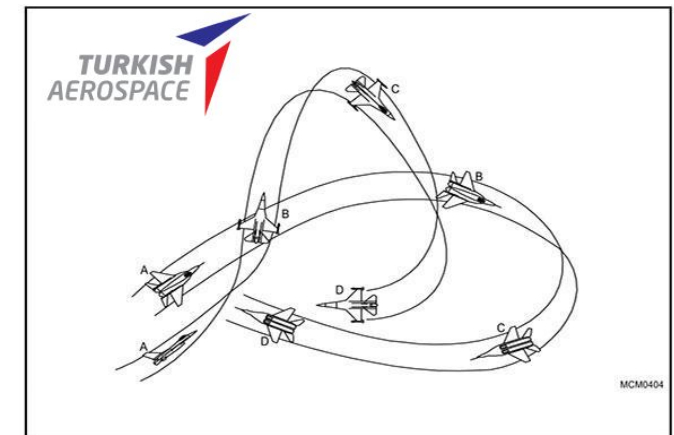

Air Combat Engagement Modelling and Simulation

R&D FACILITIES - AEROSPACE MULTIDISCIPLINARY DESIGN OPTIMIZATION LABORATORY (AeroMDO)

- Application and development of multidisciplinary design, analysis and optimization methods for air and space vehicles using different physical calculations such as aerodynamics, aerospace structures, acoustics, control, propulsion, reliability.
- Sonic Boom

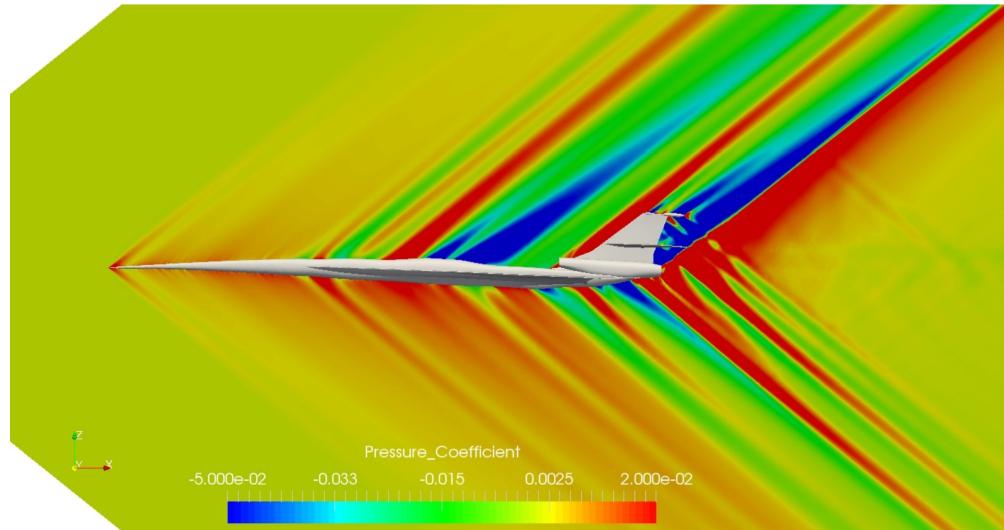

Aeroelasticity

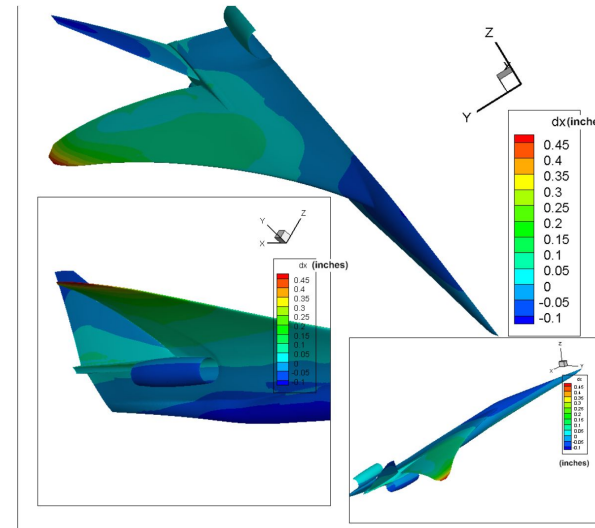

Engine Operation

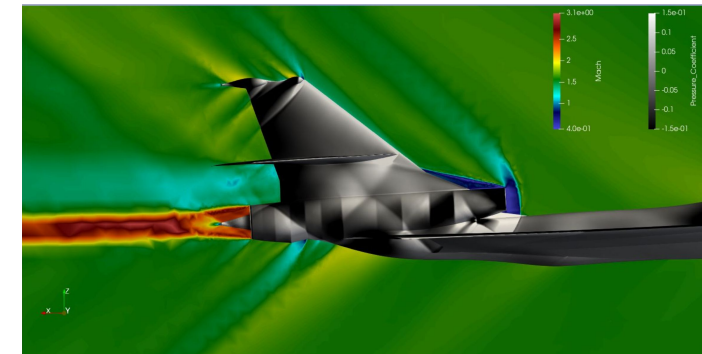

Collaborations



Optimization

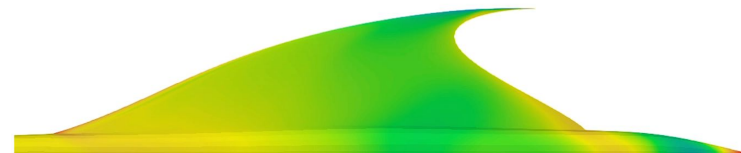

Purpose of the Laboratory:

- Next generation structural applications and smart material applications on rotary system tracks
- Experimental and theoretical studies for performance calculation
- Experimental and theoretical studies for performance enhancement and design improvement

Experiments Conducted:

- Performance Tests
- Applications of intelligent control systems with piezoelectric materials

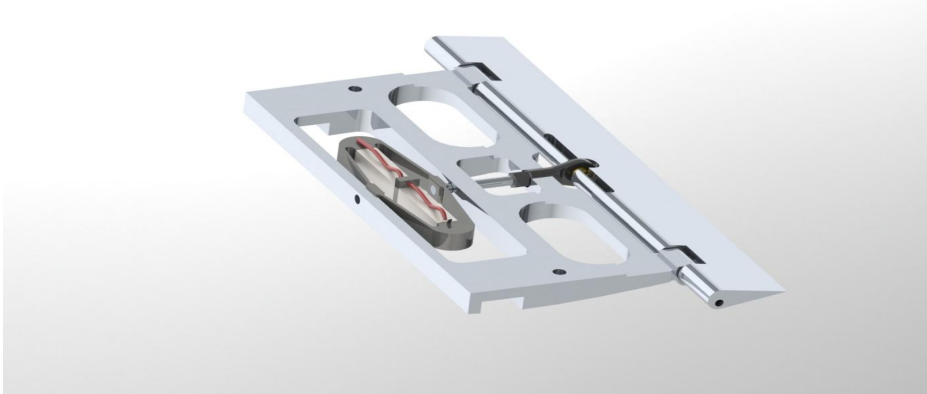
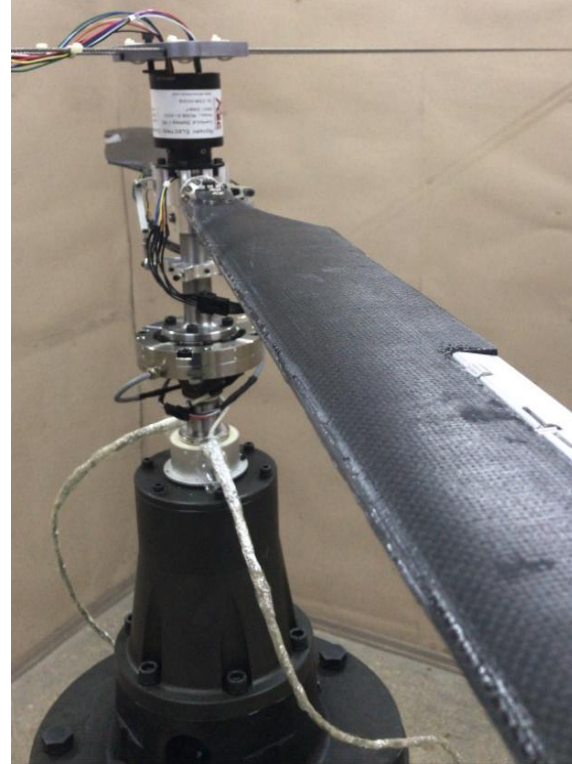

STRATEGIC BUSINESS PARTNERSHIPS

İTÜ



- ITU-TAI Long Term (Co-op) Intern Agreement
- ITU-THY Technical Long Term (Co-op) Intern Agreement
- ITU-ASELSAN Cooperation Protocol
- ITU-TAI Very Light Aircraft Project
 - +20 Engineering Students & 11 Faculty Members



TURKISH AIRLINES

aselsan



WORK OPPORTUNITIES

İTÜ



■ Defense Industry

- Turkish Aerospace Industry (TAI), Turkish Engine Industry (TEI)
- ASELSAN, HAVELSAN, ROKETSAN, TÜBİTAK SAGE, TÜBİTAK UZAY



■ Civil Aviation

- Turkish Airlines (THY)
- Commercial Airline companies (AtlasJet, Pegasus, Sun Express...)
- Aircraft Maintenance Companies (Turkish Technic, ATS Team, MNG Technic)
- Airport Operations (TAV)



■ Automotive Industry

- Mercedes, Fiat Tofas, Isuzu, BMC, Renault, Hyundai, FEV

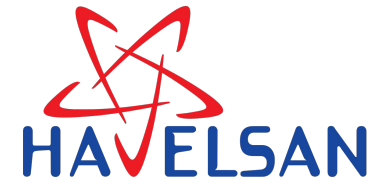

■ Air Supply Maintenance Centers (ASMC)

■ Industry (Arcelik, Beko, Infotron, AEG, Bosch, Momentus)



■ Foreign Companies

- SAFRAN, NASA, Boeing, JAXA, EUROCONTROL



Faculty Teams

- APİS
- PARS Rocket Group
- Lagari Thrust Roket Team
- High Altitude Balloon Team
- Ata Team
- İTÜ Albatros İHA Team
- Boomerang
- Nursat
- Simurg
- İTÜ Rota Team
- İTÜNOM İHA Team
- Savroket
- İTÜ BEECOPTER
- İTÜ Kovan
- İTÜ Target Team
- İTÜ SKY-UAV (S-UAV)
- İTÜ SUNGUR İHA (SİHA)
- SAVSAT Satellite Team
- METEO CODING Team
- Aerospace Engineering Club
- Meteorological Research Club
- Aviation Club
- Defense Technologies Club



IMEchE's UAS Challenge 2018 – 1st Place



AIAA's CanSat Competition 2019 – 1st Place

PROJECT TEAM ACHIVEMENTS - 2025

İTÜ



TEKNOFEST 2025 Achivements		
Team	Competition	Award
İTÜ GÖKBÖRÜ	Fighting UAV	Fourth Place
İTÜ ATA	Fighting UAV	First Place
İTÜNOM	Fighting UAV	Third Place

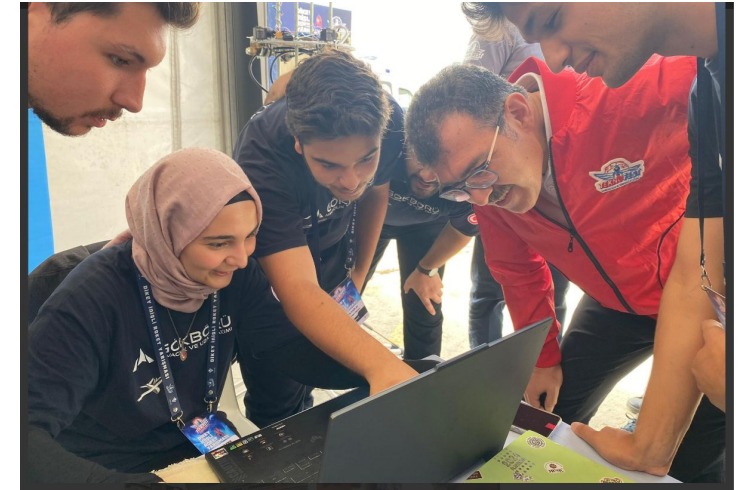

PROJECT TEAM ACHIVEMENTS - 2024

İTÜ



TEKNOFEST 2024 Achievements		
Team	Competition	Award
İTÜ VEFA Team	Spaceport America Cup'24	World Champion
İTÜ ATA	Fighting UAV	Honorable Mention Second Place
İTÜNOM	Fighting UAV	Design Award
İTUVERSE	AIAA Space Design Competition	Third Place
İTÜ Bellatrix Space Team	NASA HERC 2024	Artemis Educator Award

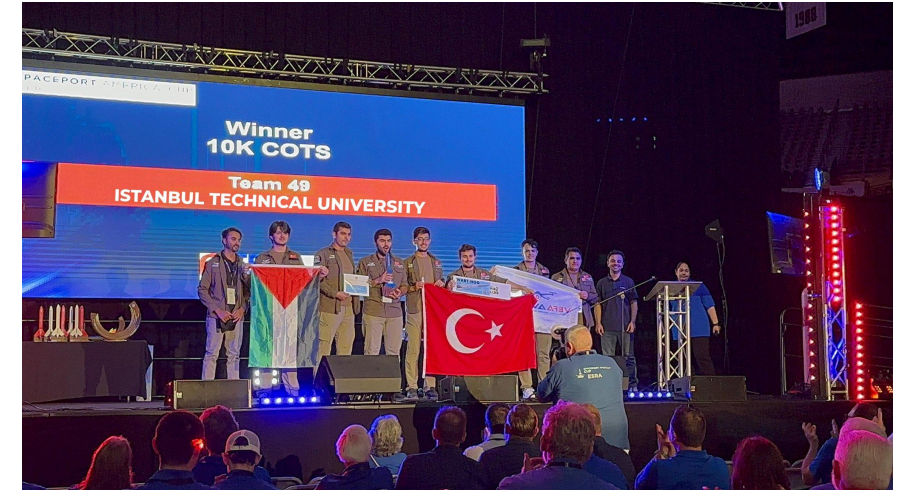

PROJECT TEAM ACHIVEMENTS - 2023

İTÜ



TEKNOFEST 2023 Achievements

Team	Competition	Award
İTÜ ALBATROS	Fighting UAV	Design Award
İTÜ ATA	Fighting UAV	Third Place
İTÜNOM	International UAV	Second Place
İTÜ SKY UAV	International UAV	Performance Award
İTÜ GÖKBÖRÜ	International UAV	Performance Award



PROJECT TEAM ACHIVEMENTS - 2022

İTÜ



TEKNOFEST 2022 Achievements

Team	Competition	Award
ITU Beecopter Team	Helicopter Design Competition	Gold Medal
Vefa Aviation Team	TÜBİTAK International Free Mission UAV Competition	Bronze Performance Award
ITU TVC Rocket Team	TÜBİTAK 2022 Vertical Landing Rocket Competition	Best Team Spirit Award
ITU Albatros Team	TÜBİTAK International Free Mission UAV Competition	Encouragement Award





Thank You